

NOTE: 1  
 DESIGN CODE:  
 NS-EN 13445

NOTE: 2  
 TECHNICAL CLASSIFICATION:  
 Article Type: 003-Valve Stabs  
 Main Group: 3.03. Ø55-Valvestab  
 Intermediate Group: 3.12.02. Receptacle  
 Sub Group: 3.12.69.6. Hexa

NOTE: 3  
 INTERFACE INFORMATION:  
 Pressure Rating Bar: 250  
 Material: Long-term  
 Weight: 20,8 kg  
 Volume: 2,7 dm<sup>3</sup>  
 Surface Area: 5023 cm<sup>2</sup>  
 Hydraulic: 3/8" MP Autoclave  
 Mechanical: N/A  
 Electrical: N/A  
 Com. & Protocol: N/A

NOTE: 4  
 SPAREPARTS:  
 BB1690

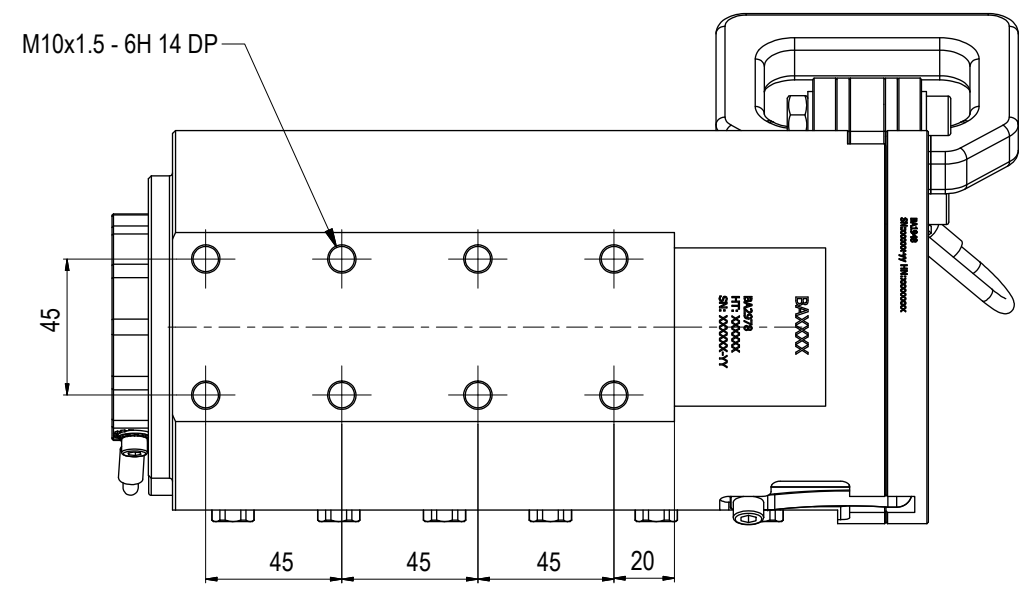
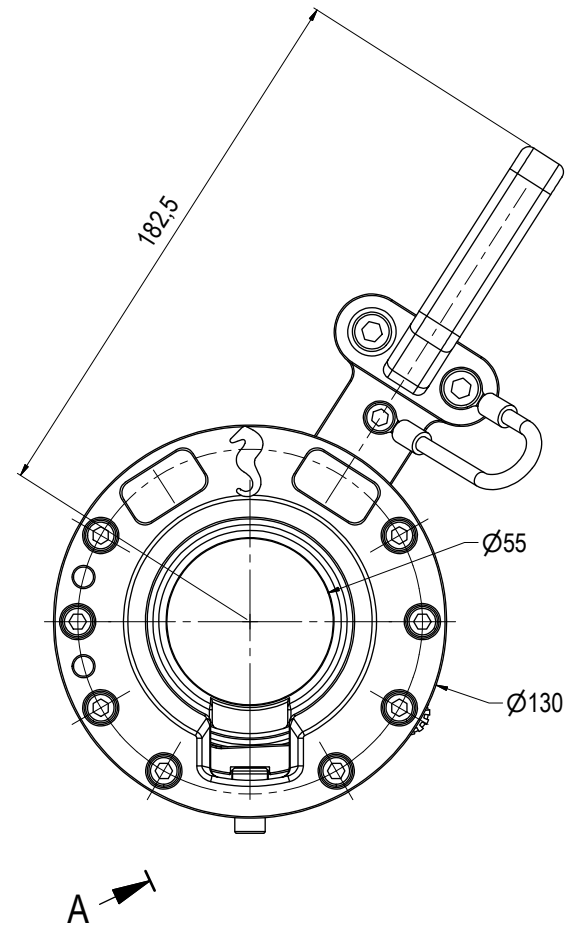
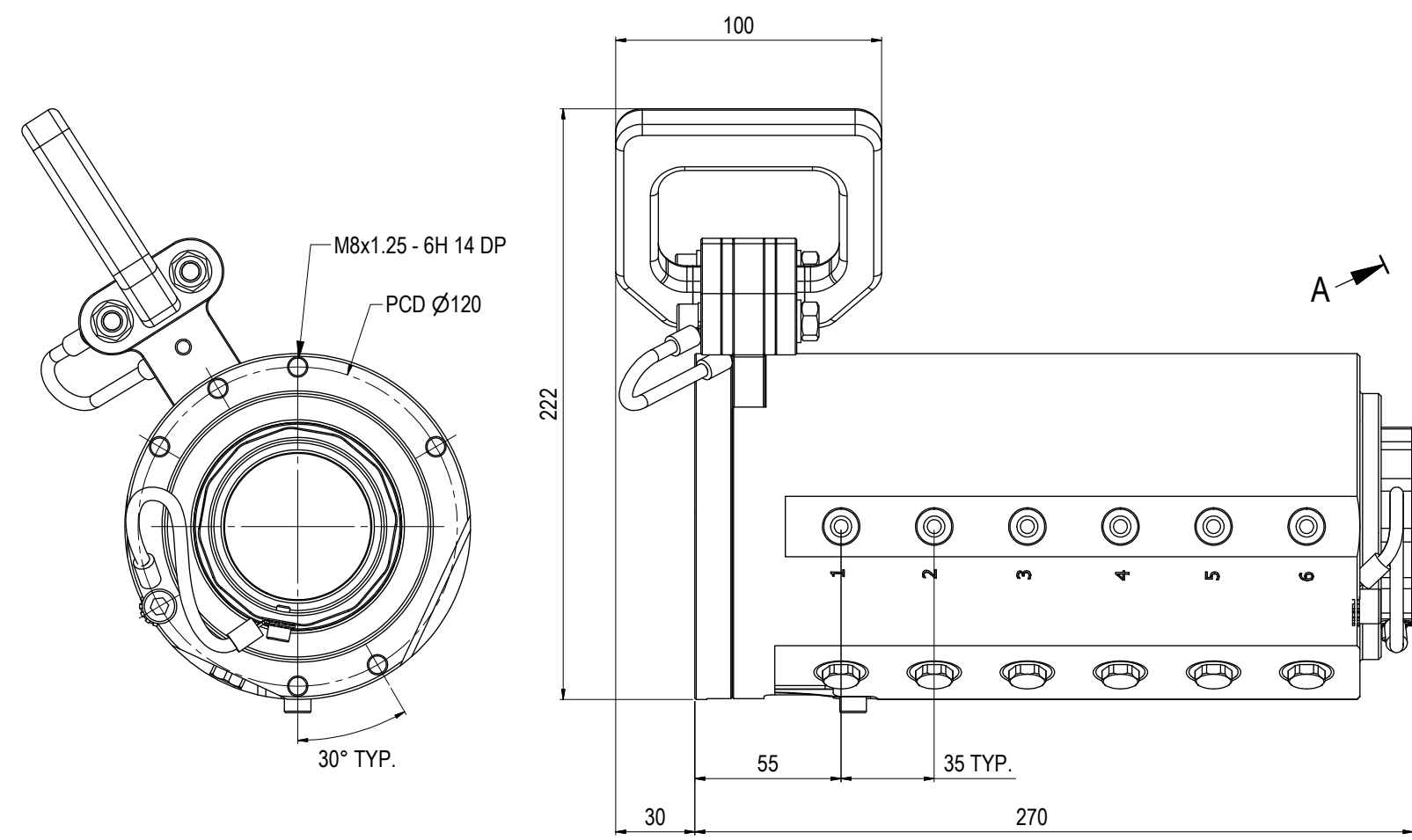

VIEW A-A

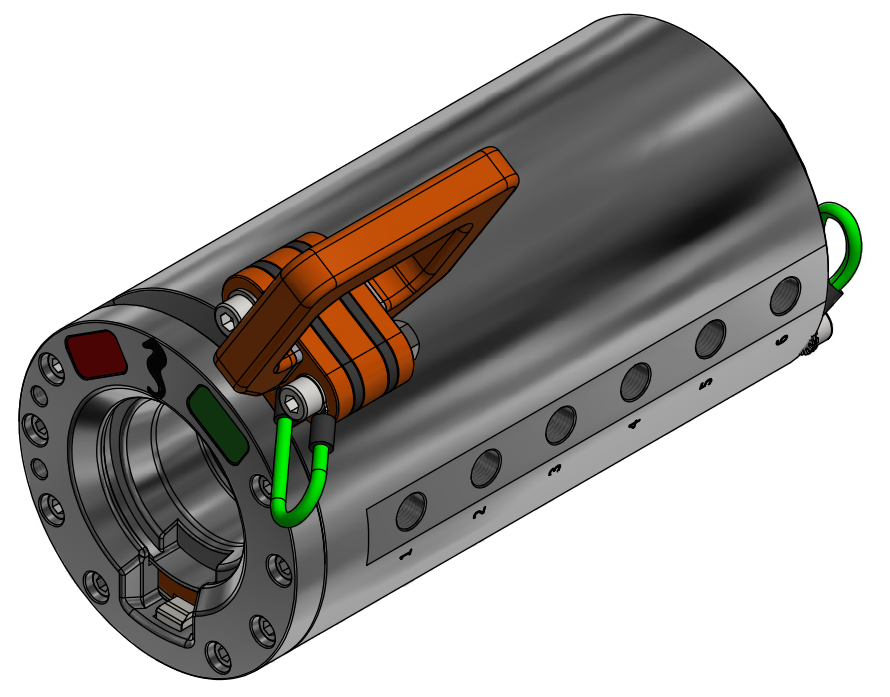

09	29.5.2024	9-IFU (Issued for Use)		WTJ	HNJ	WTJ
08	30.11.2023	9-IFU (Issued for Use)		WTJ	LGH	WTJ
07	30.1.2019	9-IFU (Issued for Use)		WTJ	LGH	WTJ
06	2.1.2019	9-IFU (Issued for Use)		WTJ	LGH	WTJ
Rev.	Date	Reason for issue	Revision change	Made	Chk'd	Appr.



Dwg Scale:  
 NTS  
 Dwg Proj:  
 Dwg Format:  
 A3

Drawing title:  
 Ø55 HP VStab Rec 250Bar Long-term Man MP 3/8"

Drawing number:  
 BA2976

Rev  
 09